

DIGITAL INDUSTRIAL IMMERSION HEATERS

Description

Applications in industrial and commercial environments often require a more accurate form of control which is why Heatrod have introduced a new range of digitally controlled immersion heaters. The HRD range of digital industrial immersion heaters are designed so the user can select a specific temperature requirement and be confident that their process will be heated in the most accurate way.

The HRD range is designed to be heavy duty with flexibility in mind, for easy installation into multiple industrial liquid heating applications. The terminal box is proven for ease of wiring and flexible for access in all types of locations. The digital controller can be programmed and wired for both single or three phase operation. Along with the standard Incoloy sheath, we also manufacture using different levels of element sheath protection depending on the environment which the heater is being installed into.



HRD Digital Immersion Heater

Technical specification

Part Number			Loading (kW)	Voltage (V)	Phase Connection	Immersed Length (in/mm)	Element Diameter (mm)	No. of Elements	Watts Density (W/cm ²)
2 ¼" BSP	2" BSP	1 ¾" BSP							
HRD311AA	HRD311BA	HRD311CA	3	240/415	1/3 PH	11/280	8	3	8.5
HRD616AA	HRD616BA	HRD616CA	6	240/415	1/3 PH	16/406	8	3	11
HRD624AA	HRD624BA	HRD624CA	6	240/415	1/3 PH	24/610	8	3	7
HRD636AA	HRD636BA	HRD636CA	6	240/415	1/3 PH	36/914	8	3	4.6
HRD916AA	HRD916BA	HRD916CA	9	415	3 PH	16/406	8	3	16.5
HRD924AA	HRD924BA	HRD924CA	9	415	3 PH	24/610	8	3	10.5
HRD936AA	HRD936BA	HRD936CA	9	415	3 PH	36/914	11	3	5.2
HRD1236AA	HRD1236BA	HRD1236CA	12	415	3 PH	36/914	11	3	6.9

Temperature range: 0-75°C, cut-out 82°C

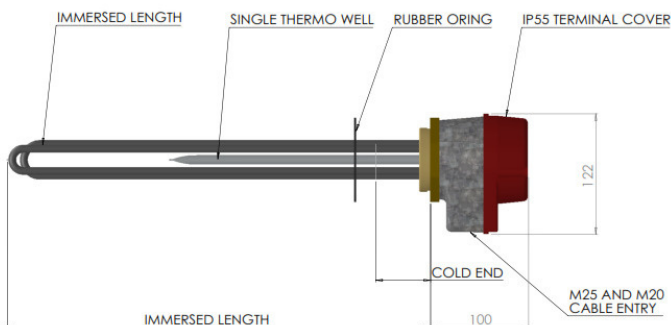

Heatrod also offer bespoke variations of the HRD range, so if the size required is not listed, please do not hesitate to contact us.

Fields of Application

FIELDS OF APPLICATION

- Oil heating
- Brewing
- Wine-making
- General process heating
- Medium/large scale water heating
- Milking & dairy systems
- Sterilisers and washers
- Engine pre-heating
- Water calorifiers (ideal for use on boats where the water is heated from the engine and standard heater controls cannot handle the high temperatures produced)



Application - Brewing

Benefits

BENEFITS

- Elements manufactured from Incoloy 825
- External input available
- IP54 rotatable terminal enclosure
- Built-in adjustable electronic thermal cut-out
- Control panels available for single and cascade control
- Unique design offers both single and three phase installation